

Transmitter Block Diagram

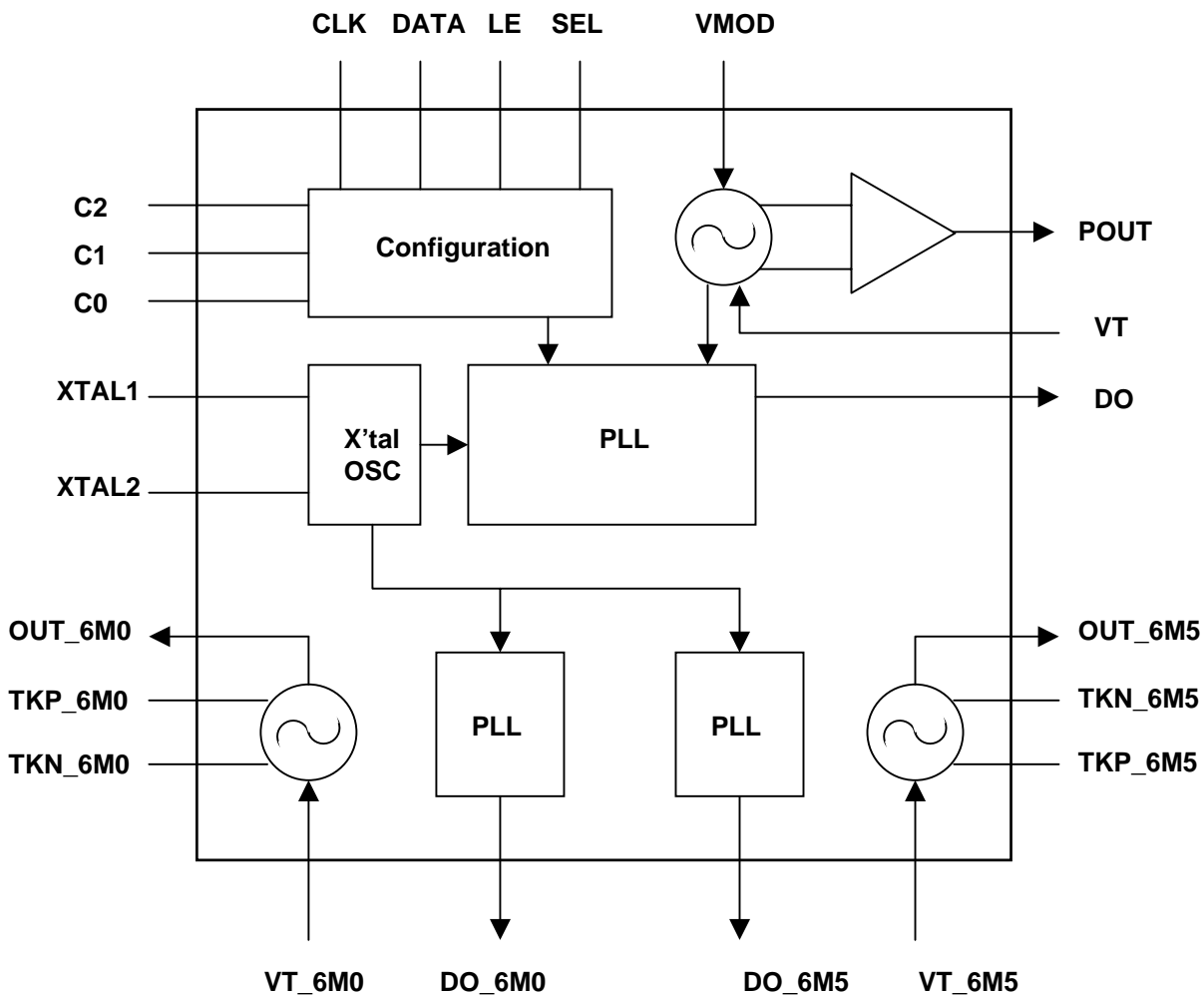
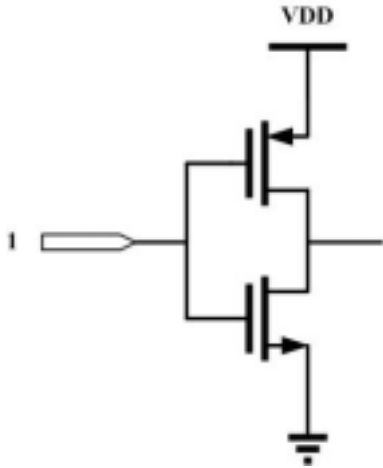
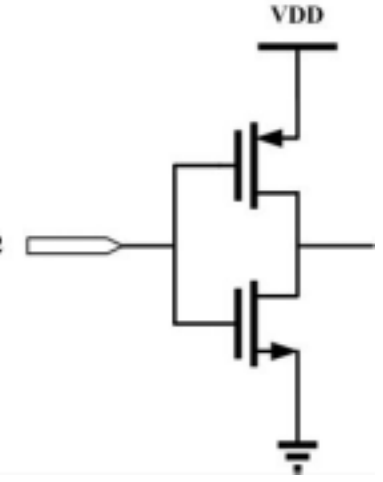
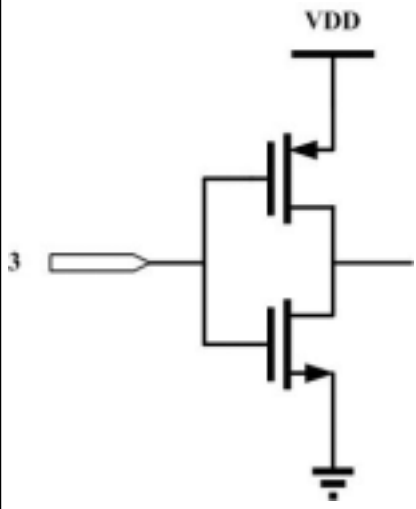
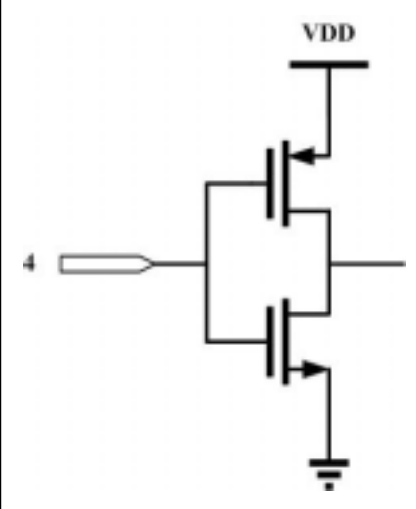

Pin Descriptions

Pin No.	Name	Description	Equivalent Schematic
1	SEL	<p>If PIN1 is unconnected (Internal pull high), the channel can be selected from a set of pre-defined channel frequencies by the settings of C0,C1,C2. If PIN1 is connected to GND, the channel frequencies can be programmed by an external MCU via the 3-wire serial interface, LE, DATA and CLK. See Note1</p>	
2	LE	<p>Load Enable Input of 3-wire Series Interface</p> <p>PIN2 is enabled when SEL (PIN1) is connected to ground</p>	

Pin No.	Name	Description	Equivalent Schematic
3	DATA	<p>DATA Input of 3-wire Series Interface</p> <p>PIN3 is enabled when SEL (PIN1) is connected to ground</p>	
4	CLK	<p>CLOCK Input of 3-wire Series Interface</p> <p>PIN4 is active when SEL (PIN1) is connected to ground</p>	

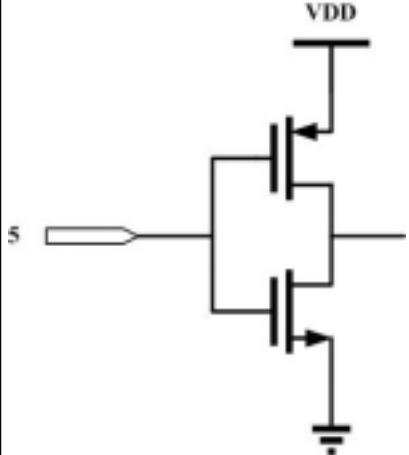
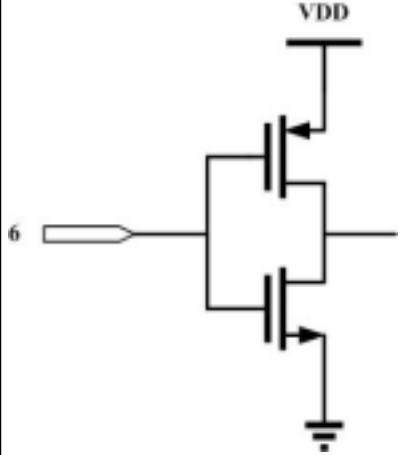
Pin No.	Name	Description	Equivalent Schematic
5	C2	<p>Internal pull high, set PIN5 Low to select CH3 (2450MHz)</p> <p>PIN5 is enabled when SEL (PIN1) is open</p> <p>See Note1</p>	
6	C1	<p>Internal pull high, set PIN6 Low to select CH2 (2432MHz)</p> <p>PIN6 is enabled when SEL (PIN1) is open</p> <p>See Note1</p>	

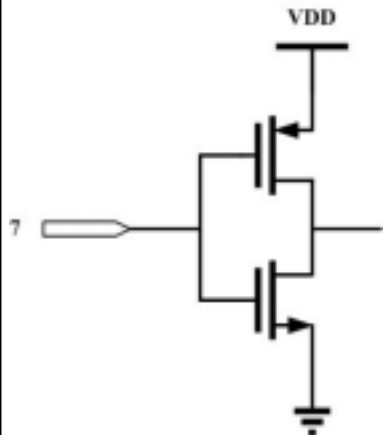
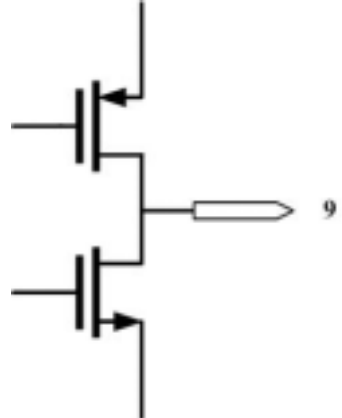

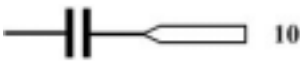
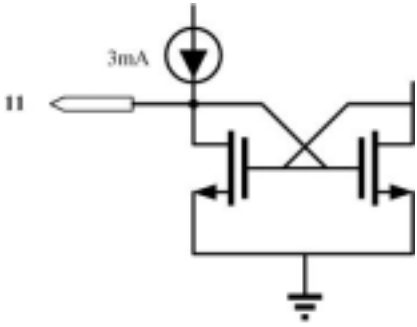
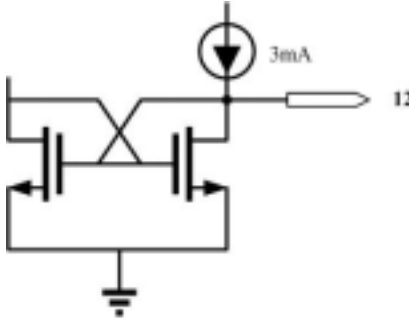
Pin No.	Name	Description	Equivalent Schematic
7	C0	<p>Internal pull high, set PIN7 Low to select CH1 (2414MHz)</p> <p>PIN7 is enabled when SEL (PIN1) is open</p> <p>See Note1</p>	
8	VDD_D_6M0	<p>Power supply for digital portion of 6.0MHz Audio Modulator</p> <p>Suggestion value of bypass capacitor C21 is 0.1uF.</p>	
9	DO_6M0	<p>Charge Pump Output of 6.0MHz PLL</p>	

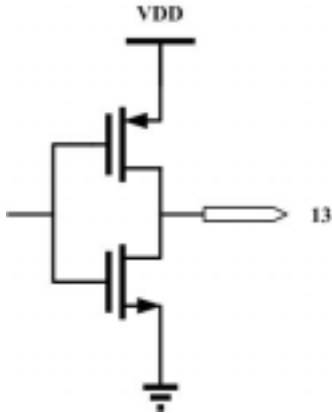
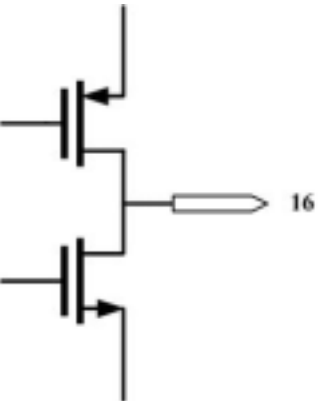
Pin No.	Name	Description	Equivalent Schematic
10	VT_6M0	6.0MHz VCO Tuning Voltage Control Input : Typical range of Vt is 1.05 ~ 1.45V.	
11	TKP_6M0	One of the two connection pins for external Tank components of 6.0MHz VCO. Shorter traces for the interconnection of L and C are recommended. Suggestion values of L5 and C24 are 33uH and 10pF.	
12	TKN_6M0	One of the two connection pins for external Tank components of 6.0MHz VCO. Shorter traces for the interconnection of L and C are recommended. Suggestion values of L5 and C24 are 33uH and 10pF.	

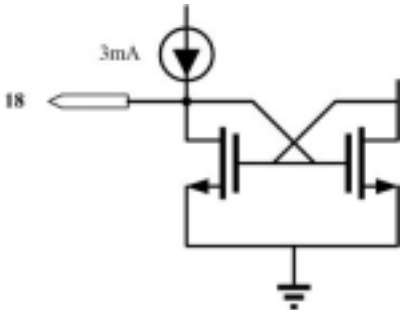
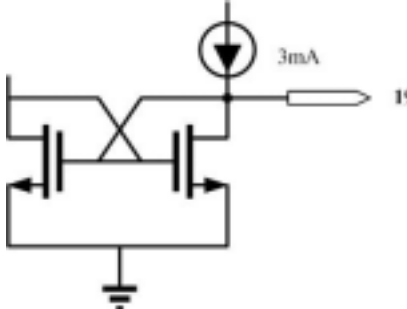
Pin No.	Name	Description	Equivalent Schematic
13	OUT_6M0	6.0MHz Audio Modulator Output	
14	VDD_A_6M0	Power supply for analog portion of 6.0MHz Audio Modulator. Suggestion values of bypass capacitor C25 is 0.1uF.	
15	VDD_D_6M5	Power supply for digital portion of 6.5MHz Audio Modulator. Connect to VDD_A_6M0 (PIN14).	
16	DO_6M5	6.5MHz PLL Charge Pump Output	

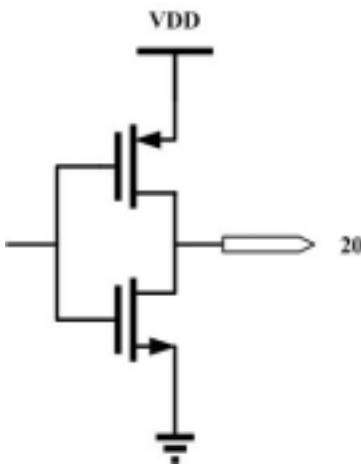
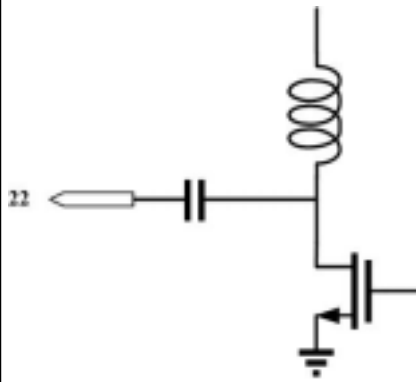
Pin No.	Name	Description	Equivalent Schematic
17	VT_6M5	6.5MHz VCO Tuning Voltage Control Input : Typical range of Vt is 1.05 ~ 1.45V.	
18	TKP_6M5	One of the two connection pins for external Tank components of 6.5MHz VCO. Shorter traces for the interconnection of L and C are recommended. Suggestion values of L4 and C26 are 33uH and 6.8pF.	
19	TKN_6M5	One of the two connection pins for external Tank components of 6.5MHz VCO. Shorter traces for the interconnection of L and C are recommended. Suggestion values of L4 and C26 are 33uH and 6.8pF.	

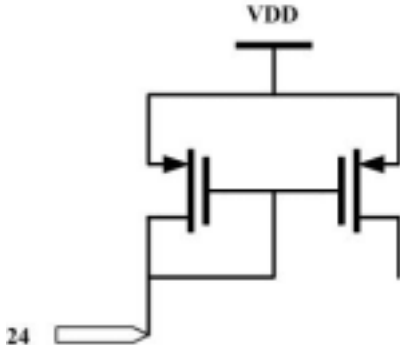
Pin No.	Name	Description	Equivalent Schematic
20	OUT_6M5	6.5MHz Audio Modulator Output	
21	VDD_A_6M5	Power supply for analog portion of 6.5MHz Audio Modulator. Suggestion value of bypass capacitor C16 is 0.1uF.	
22	POUT	2.4GHz RF Amplifier Output. Typical output power range is -2dBm ~ +1dBm.	

Pin No.	Name	Description	Equivalent Schematic
23	VMOD	FM/FSK modulation signal input of 2.4GHz VCO	
24	RES	<p>External Bias Resistor for setting 2.4GHz VCO bias current</p> <p>For optimal phase noise performance, a suggestion value of R17 is 12KΩ.</p>	
25	VDD_GR	<p>Power supply for Guard Ring.</p> <p>Suggestion values of bypass capacitors C7 and C8 are 0.1uF and 100pF.</p>	
26	VDD_R	<p>Power Supply for 2.4GHz VCO.</p> <p>Connect to VDD_GR (PIN25).</p>	
27	VT	2.4GHz VCO Tuning Voltage Control Input, Connect to LPF output	

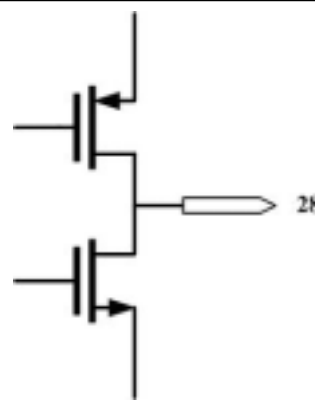
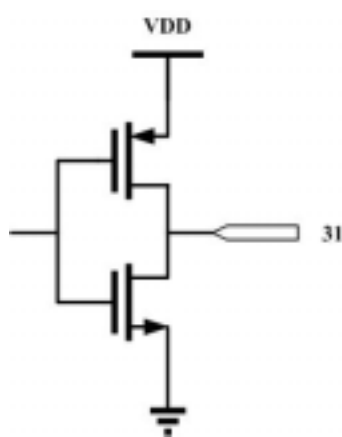
Pin No.	Name	Description	Equivalent Schematic
28	DO	2.4GHz PLL Charge Pump Output	
29	VDD_CP	Power supply for Charge Pump. Suggestion value of bypass capacitor C4 is 0.1uF.	
30	VDD_P	Prescaler Power Supply : Connect to VDD_CP (PIN29)	
31	XTAL1	One of the two connection pins of external crystal See Note2	

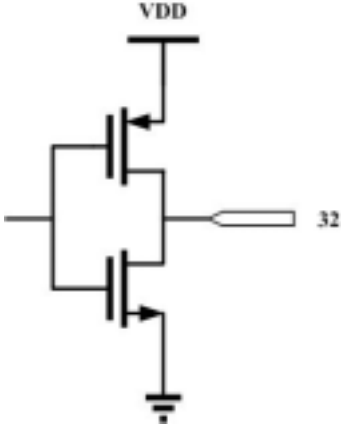
Pin No.	Name	Description	Equivalent Schematic
32	XTAL2	<p>One of the two connection pins of external crystal</p> <p>See Note2</p>	

Maximum Rating

Parameter	Maximum Rating	Units
Supply Voltage (VDD)	5	V
Storage Temperature	-20 ~ +70	

Note : This device is ESD sensitive. Handling and assembly of this device should only be done at proper ESD protection environment.

Electrical Characteristics

Parameter	Description	Min.	Typ.	Max.	Unit
Operation Temperature		-10		60	
Supply Voltage		3.0		3.7	V
Current Consumption			32		mA
Output Power		-2	1	2	dBm
Reference Frequency			8		MHz
Crystal Accuracy			30		ppm
Operation Frequency (SEL : High)		2414, 2432, 2450, 2468			MHz
6.0MHz Audio Modulator Output Level		2.5		3	Vpp
6.5MHz Audio Modulator Output Level		2.5		3	Vpp

Application Circuit: 630TX Block Diagram

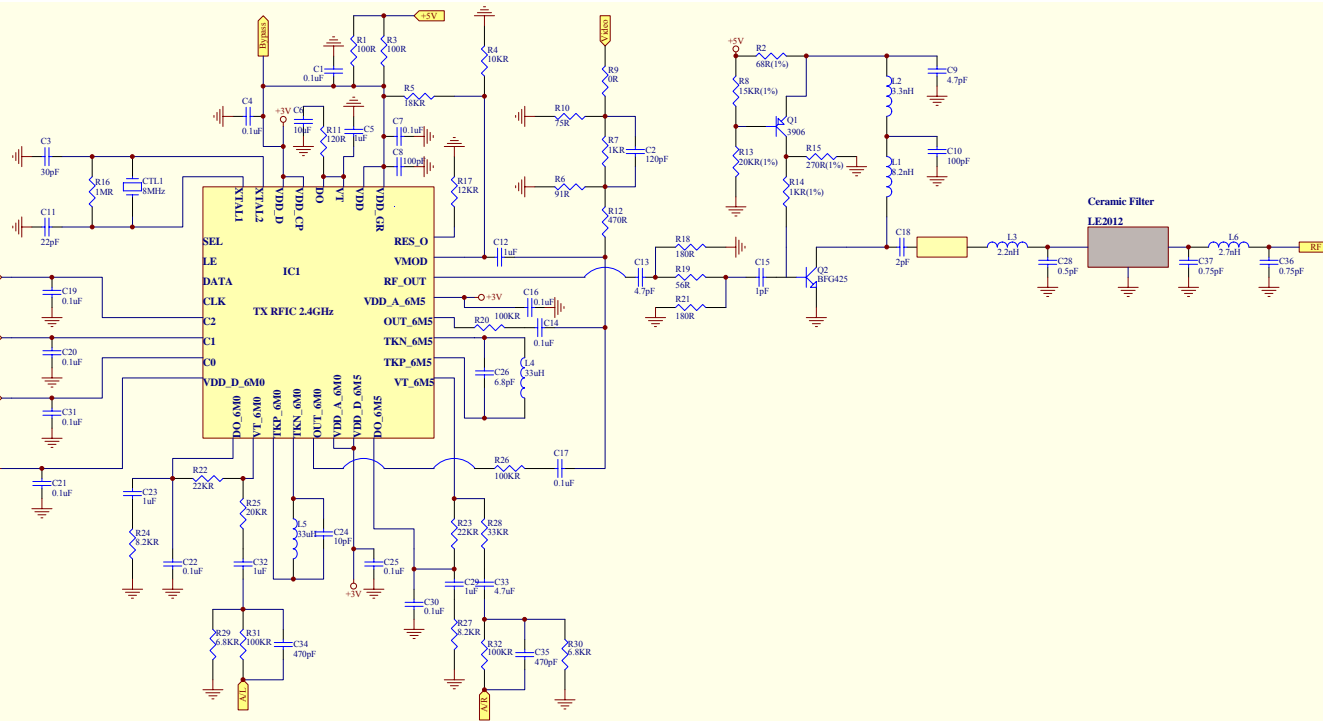

Note:

1. Channel Selection : SEL, C2, C1, C0 (PIN1, PIN5, PIN6, PIN7)

If SEL(PIN1) is unconnected (internal pull high) then connect **C2, C1, C0** to a 3 pins DIP switch to select the RF channel according to Table1.

Note: **C2, C1, C0** are internal pull high and are enabled when connected to ground. When more than one pins are low, the lowest channel is the selected one (e.g. CH1 is selected when both C0 and C1 are low). If no pins are connected to ground, CH4 is the default channel.

CH	Frequency	C2	C1	C0
1	2414MHz	1	1	0
2	2432MHz	1	0	1
3	2450MHz	0	1	1
4	2468MHz	1	1	1

Table1

2. XTAL1 (PIN31) and XTAL2 (PIN32)

Figure.1 shows the recommended crystal oscillator circuit diagram. The resistor Rf is connected in parallel with the crystal and between the input and output of the inverter to provide a negative DC feedback. Usually, the range of its resistance value is 500K ~ 2M .

The capacitors C1 and C2 provide the necessary load capacitance for resonating the crystal. Their values can be determined by the following equation:

$$C_L = \frac{C_1 * C_2}{C_1 + C_2} + C_s$$

where CL is the load capacitance of the crystal whose value can be obtained from the data sheet provided by the crystal manufacturer and Cs is the stray capacitance on the printed circuit board. A typically value of Cs is 0.3~0.6pF. Larger values of C1and C2 increases frequency stability but decreases loop gain. Suggestion values of C1, C2 and Rf are 22pF, 30pF and 1M , respectively.

Note:

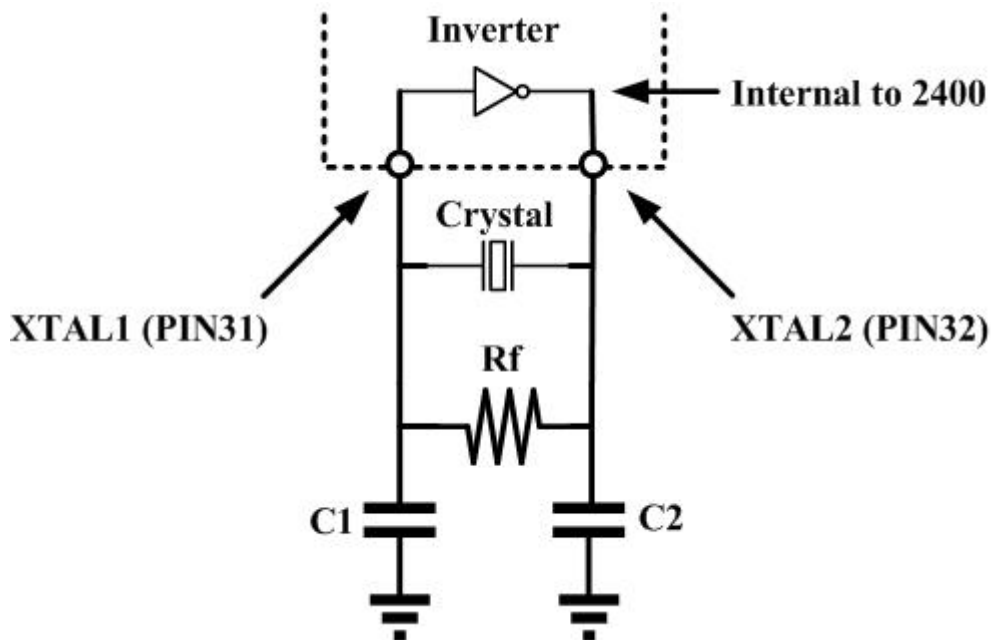
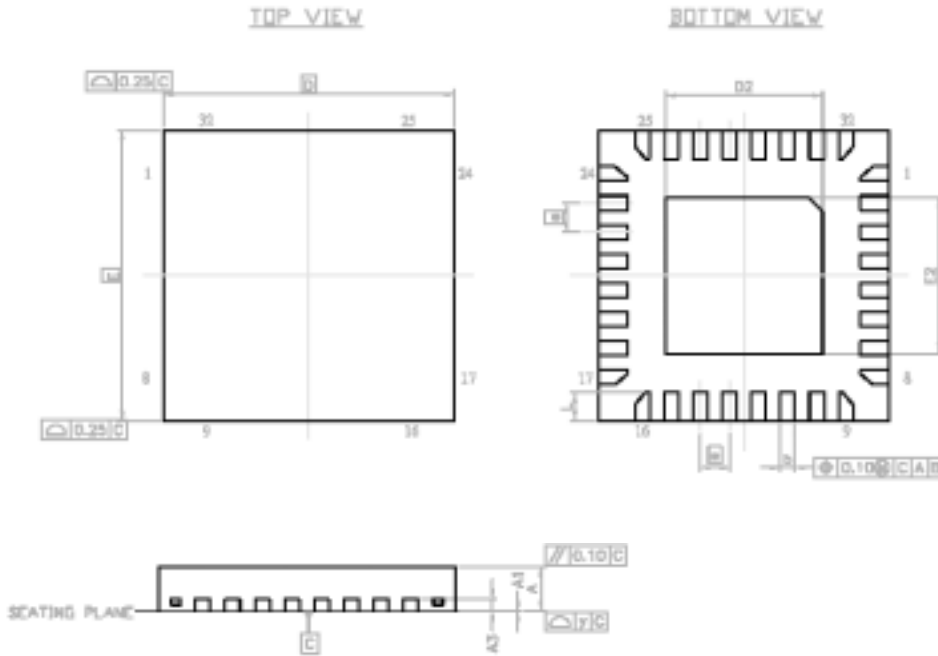

Figure1

Package Information

QFN 32 Outline Dimensions



SYMBOL	DIMENSION (MM)			DIMENSION (MIL)		
	MIN.	NOM.	MAX.	MIN.	NOM.	MAX.
A	0.70	0.75	0.80	27.6	29.5	31.5
A1	0	0.02	0.05	0	0.8	2.0
A3	0.20 REF			9.8 REF		
b	0.18	0.25	0.30	7.1	9.8	11.8
D	5.00 BSC			196.9 BSC		
D2	2.60	2.70	2.80	102.4	106.3	110.2
E	5.00 BSC			196.9 BSC		
E2	2.60	2.70	2.80	102.4	106.3	110.2
e	0.50 BSC			19.7 BSC		
L	0.30	0.40	0.50	11.8	15.7	19.7
y	0.10			3.9		