

Product Description

The AWI2422 is an integrated single chip receiver designed for analog A/V sender and wideband digital FSK receiver operating in the 2.4GHz ISM band. The receiver IC consists of a fully integrated frequency synthesizer, LNA, Mixer, IF Amplifier, PLL FM Demodulator, Audio Demodulator and Audio OP Amplifier. The IC is provided in 48-lead QFN7X7 package and is designed to provide a fully functional FM/FM receiver.

Main Features

- Low cost , single chip FM/FSK receiver IC
- 3.6V power Supply
- 4 channels operation for analog A/V sender and digital FSK transmission applications
- Channel select by use of c0,c1,c2 and c3 pins
- Integrated stereo Sound Demodulator and Audio OP Amplifiers

Pin Configurations

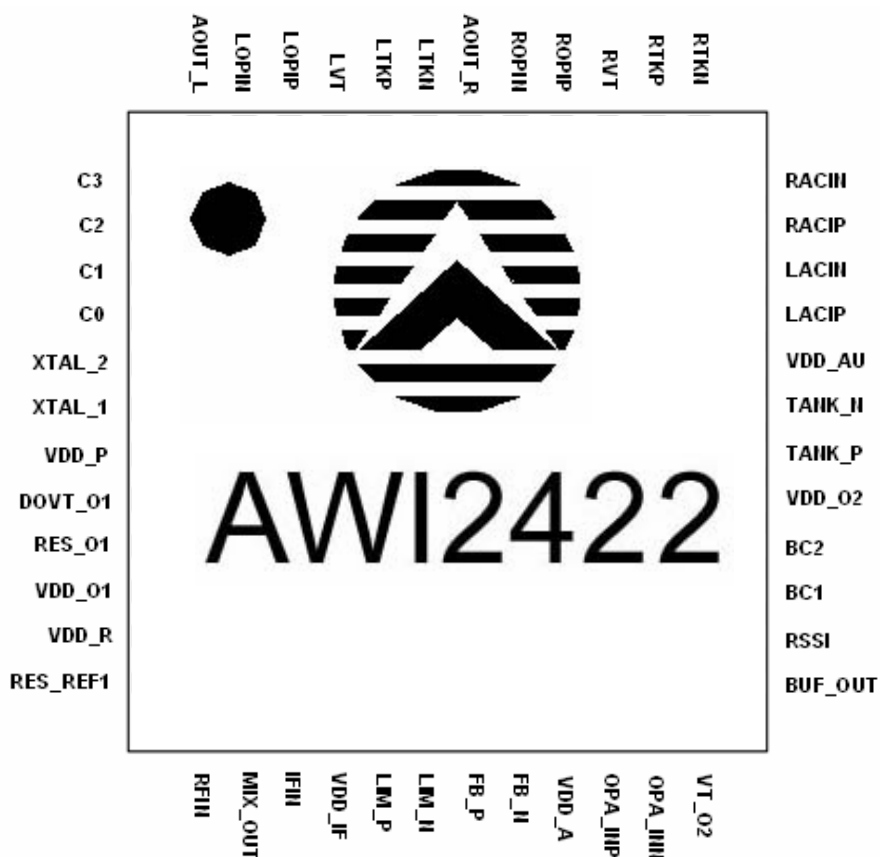

Receiver Block Diagram

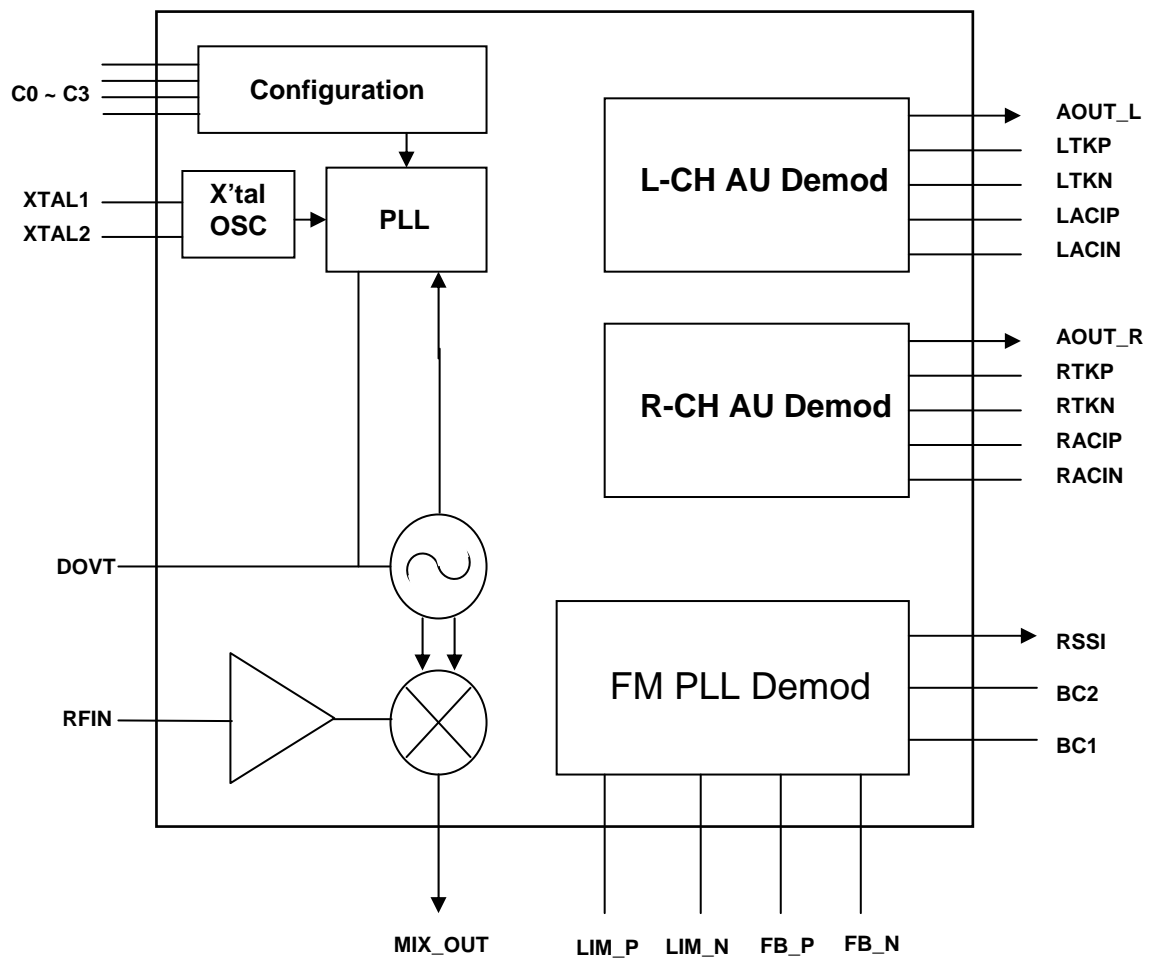

Pin Descriptions

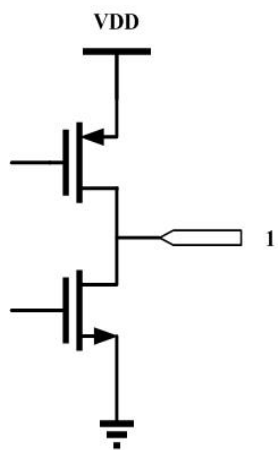
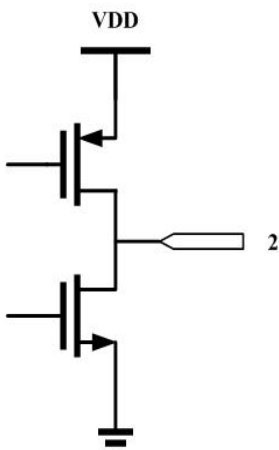
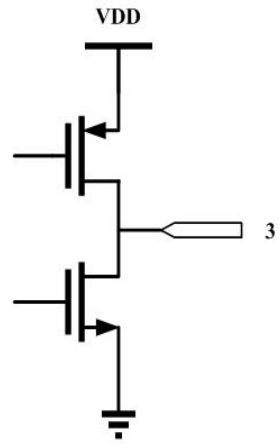
Pin No.	Name	Description	Equivalent Schematic
1	C3	<p>Internal pull high, set PIN2, PIN3, PIN4 High to select CH4. (2468MHz)</p> <p>A series inductor L13 of 100nH is recommended for the suppression of LO and Spurs.</p>	
2	C2	<p>Internal pull high, set PIN2 Low to select CH3. (2450MHz)</p> <p>A series inductor L19 of 100nH is recommended for the suppression of LO and Spurs.</p>	
3	C1	<p>Internal pull high, set PIN3 Low to select CH2. (2432MHz)</p> <p>A series inductor L18 of 100nH is recommended for the suppression of LO and Spurs.</p>	

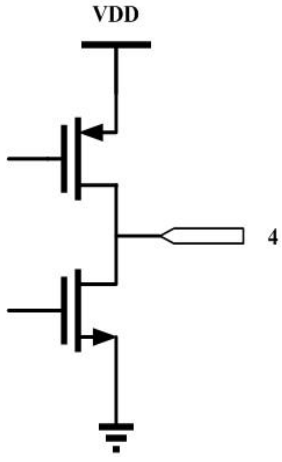
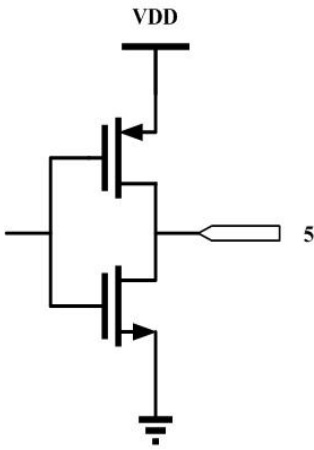
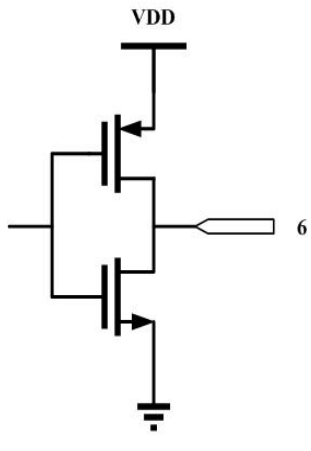
Pin No.	Name	Description	Equivalent Schematic
4	C0	<p>Internal pull high, set PIN4 Low to select CH1. (2414MHz)</p> <p>A series inductor L22 of 100nH is recommended for the suppression of LO and Spurs.</p>	
5	XTAL_2	One of the two connection pins of external crystal	
6	XTAL_1	One of the two connection pins of external crystal	

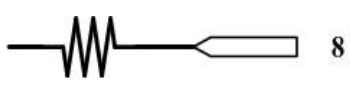
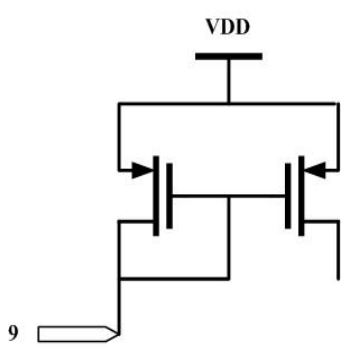
Pin No.	Name	Description	Equivalent Schematic
7	VDD_P	Prescaler Power Supply : Suggestion value of bypass capacitor C43 is 100pF.	
8	DOVT_O1	1.9GHz LO Tuning Voltage Control Input : Typical range of Vt is 0.5V ~ 2V.	
9	RES_O1	External Bias Resistor for setting 1.9GHz VCO bias current : For optimal phase noise performance, the suggestion value of R19 is 10KΩ.	
10	VDD_O1	1.9GHz VCO Power Supply : Suggestion value of bypass capacitor C38 is 4.7pF.	
11	VDD_R	LNA Power Supply : Suggestion value of bypass capacitor C34 is 6.8pF.	

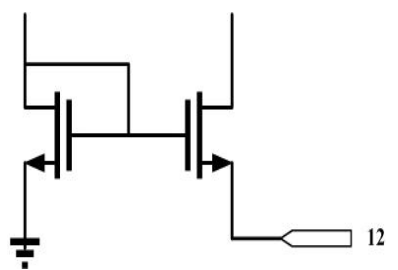
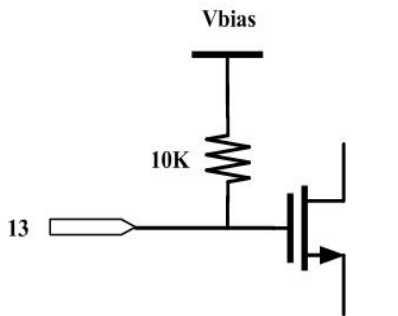
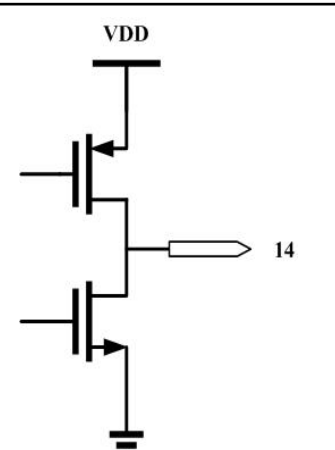
Pin No.	Name	Description	Equivalent Schematic
12	RES_REF1	<p>External Bias Resistor for setting 2.4GHz LNA bias current</p> <p>For optimal gain and noise performance, a suggestion value of R16 is 18KR.</p>	
13	RFIN	RF Input to internal LNA	
14	MIX_OUT	<p>Mixer Output :</p> <p>The impedance level of MIX_OUT (PIN14) and IF Filter is 50Ω.</p>	

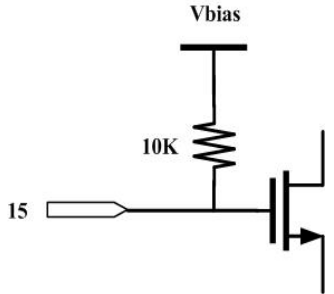
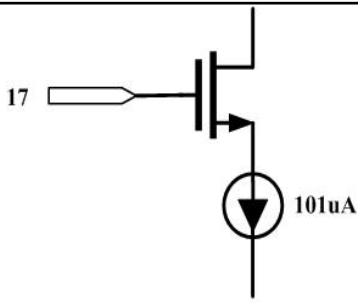
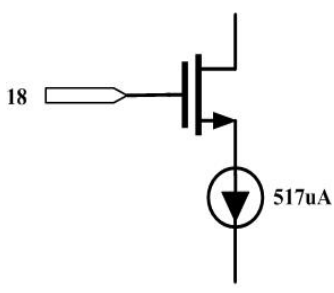
Pin No.	Name	Description	Equivalent Schematic
15	IFIN	IF Input to internal IF Amplifier The impedance level of IF_IN (PIN15) is 50Ω.	
16	VDD_IF	Open drain of IF Amplifier output stage IF Amplifier power supply	
17	LIM_P	Limiting Amplifier Positive Input	
18	LIM_N	Limiting Amplifier Negative Input	

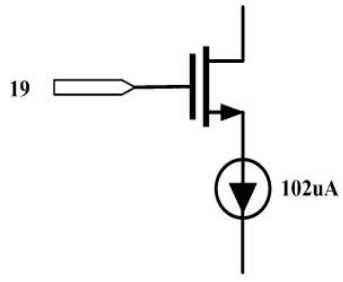
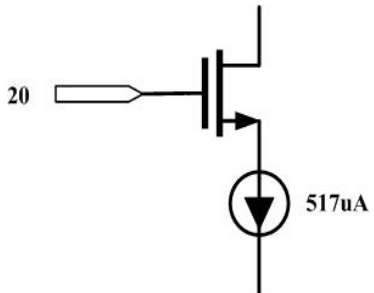
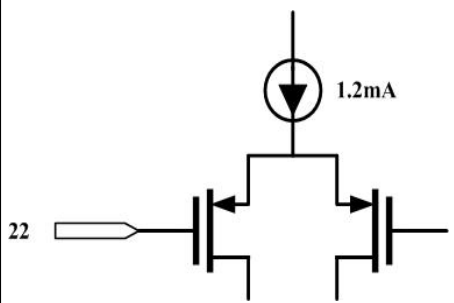
Pin No.	Name	Description	Equivalent Schematic
19	FB_P	Limiting Amplifier Feedback Input (Positive node)	
20	FB_N	Limiting Amplifier Feedback Input (Negative node)	
21	VDD_A	Demodulator Power Supply : Suggestion values of bypass capacitor C15 and C23 are 0.1uF and 1nF.	
22	OPA_INP	OPA Positive Input	

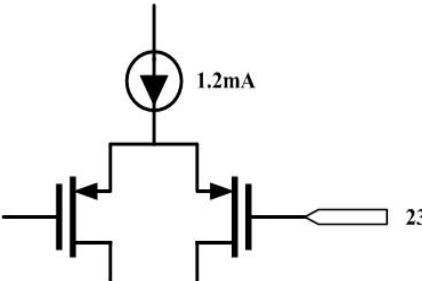
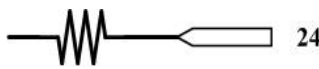
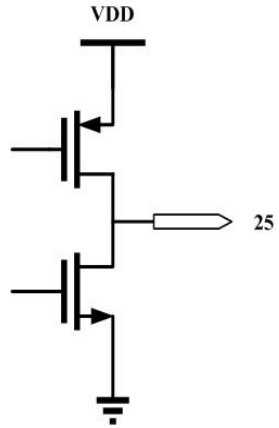
Pin No.	Name	Description	Equivalent Schematic
23	OPA_INN	OPA Negative Input	
24	VT_O2	480MHz VCO Tuning Voltage Control Input : The typical range of V_t is 0.7V ~ 1.3V. Fine tuning of V_t can be obtained by different settings of BC1, BC2.	
25	BUF_OUT	Demodulated Signal Output	

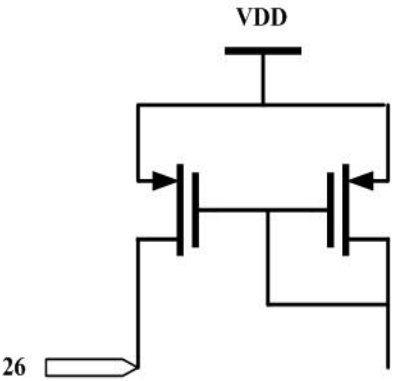
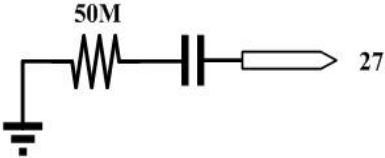
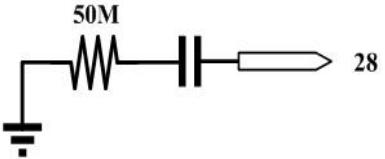
Pin No.	Name	Description	Equivalent Schematic
26	RSSI	<p>RSSI Output :</p> <p>The RSSI output voltage is inversely proportional to input signal strength. Typical range of RSSI output voltage is 1 ~ 1.9V.</p>	
27	BC1	<p>480MHz VCO Frequency Tuning Control Bit : 1C (C: unit capacitance)</p> <p>Internal pull high, set PIN27 Low to add the extra tuning capacitance.</p>	
28	BC2	<p>480MHz VCO Frequency Tuning Control Bit : 2C (C: unit capacitance)</p> <p>Internal pull high, set PIN28 Low to add the extra tuning capacitance.</p>	
29	VDD_O2	<p>480MHz VCO Power Supply :</p> <p>Suggestion value of bypass capacitor C32 is 100pF.</p>	

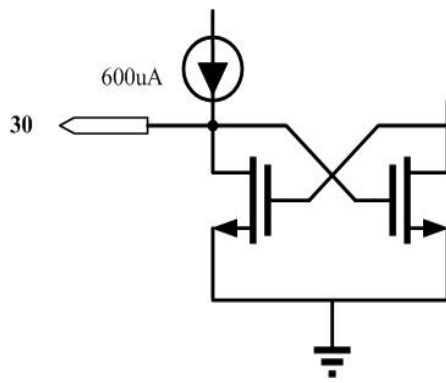
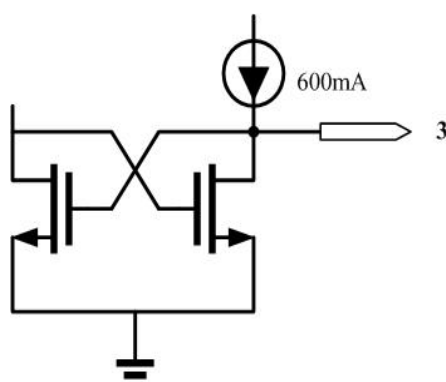
Pin No.	Name	Description	Equivalent Schematic
30	TANK_P	<p>One of the two connection pins for external Tank components of 480MHz VCO.</p> <p>Shorter traces for the interconnection of L and C are recommended.</p> <p>Suggestion values of L15 and C41 are 27nH and 1.5pF.</p>	
31	TANK_N	<p>One of the two connection pins for external Tank components of 480MHz VCO.</p> <p>Shorter traces for the interconnection of L and C are recommended.</p> <p>Suggestion values of L15 and C41 are 22nH and 1.8pF.</p>	
32	VDD_AU	<p>Audio Power Supply :</p> <p>Suggestion value of bypass capacitor C40 is 0.1uF.</p>	

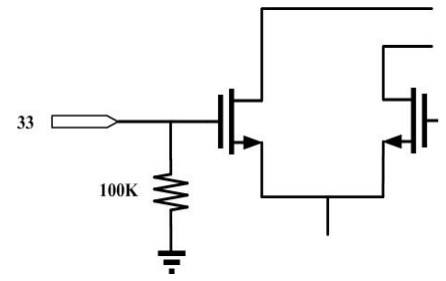
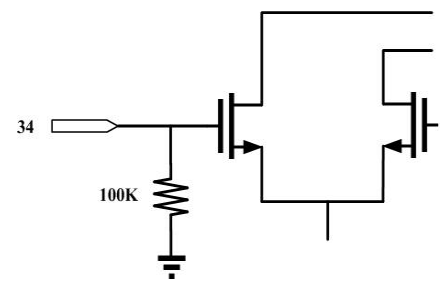
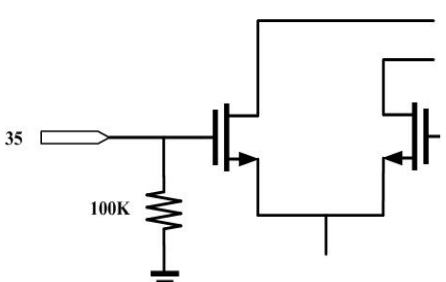
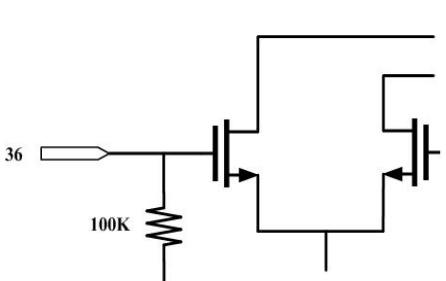
Pin No.	Name	Description	Equivalent Schematic
33	LACIP	6.0MHz Limiting Amplifier Positive Input	
34	LACIN	6.0MHz Limiting Amplifier Negative Input	
35	RACIP	6.5MHz Limiting Amplifier Positive Input	
36	RACIN	6.5MHz Limiting Amplifier Negative Input	

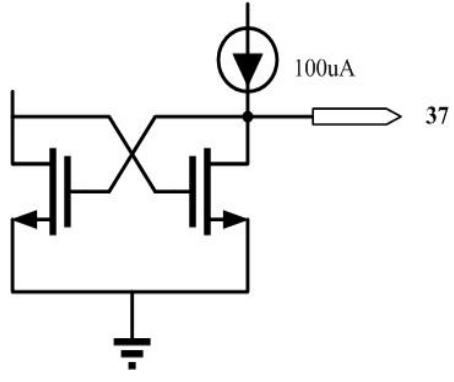
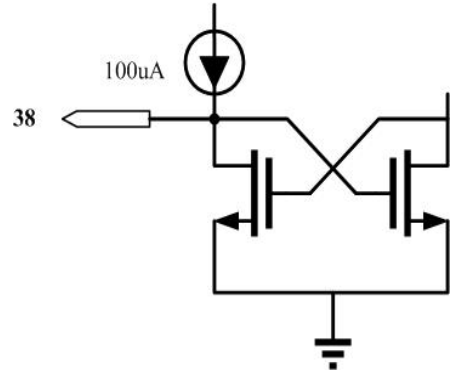
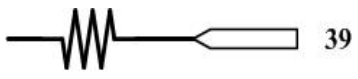
Pin No.	Name	Description	Equivalent Schematic
37	RTKN	<p>One of the two connection pins for external Tank components of 6.5MHz VCO.</p> <p>Shorter traces for the interconnection of L and C are recommended.</p> <p>Suggestion values of L20 and C48 are 33uH and 6.8pF.</p>	
38	RTKP	<p>One of the two connection pins for external Tank components of 6.5MHz VCO.</p> <p>Shorter traces for the interconnection of L and C are recommended.</p> <p>Suggestion values of L20 and C48 are 33uH and 6.8pF.</p>	
39	RVT	<p>6.5MHz VCO Tuning Voltage Control Input : The range of Vt is 1.1 ~ 1.5V.</p>	

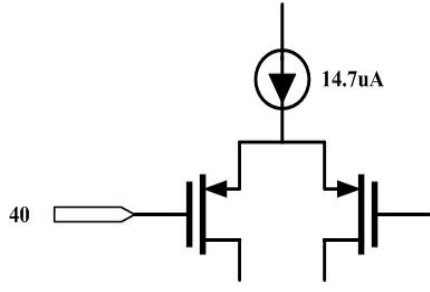
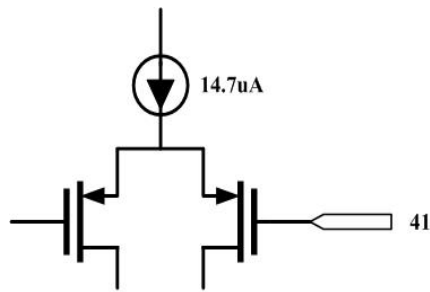
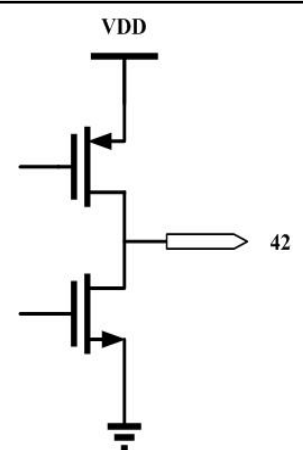
Pin No.	Name	Description	Equivalent Schematic
40	ROPIP	Positive Input of Right CH Audio OPA	
41	ROPIN	Negative Input of Right CH Audio OPA	
42	AOUT_R	Audio Output of Right CH Audio OPA	

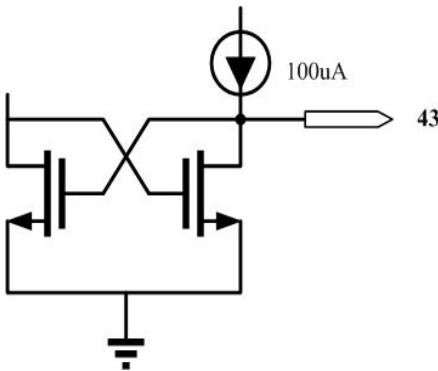
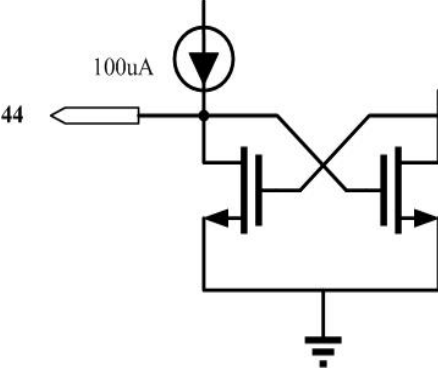
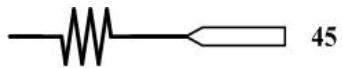
Pin No.	Name	Description	Equivalent Schematic
43	LTKN	<p>One of the two connection pins for external Tank components of 6.0MHz VCO.</p> <p>Shorter traces for the interconnection of L and C are recommended.</p> <p>Suggestion values of L21 and C49 are 33uH and 10pF.</p>	
44	LTKP	<p>One of the two connection pins for external Tank components of 6.0MHz VCO.</p> <p>Shorter traces for the interconnection of L and C are recommended.</p> <p>Suggestion values of L21 and C49 are 33uH and 6.8pF.</p>	
45	LVT	<p>6.0MHz VCO Tuning Voltage Control Input : Typical range of Vt is 1 ~ 1.4V.</p>	

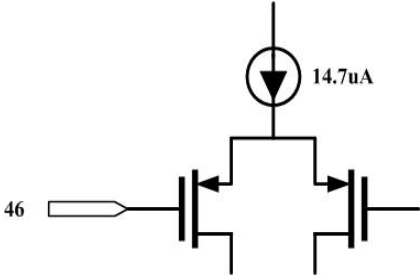
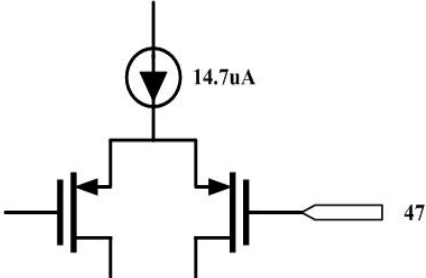
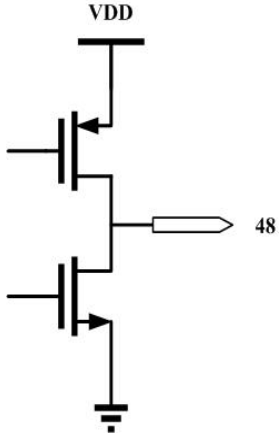
Pin No.	Name	Description	Equivalent Schematic
46	LOPIP	Positive Input of Left CH Audio OPA	
47	LOPIN	Negative Input of Left CH Audio OPA	
48	AOUT_L	Audio Output of Left CH Audio OPA	

Maximum Rating

Parameter	Maximum Rating	Units
Supply Voltage (VDD)	5	V
Storage Temperature	-20 ~ +70	°C

Note : This device is ESD sensitive. Handling and assembly of this device should only be done at proper ESD protection environment.

Electrical Characteristics

Parameter	Description	Min.	Typ.	Max.	Unit
Operation Temperature		-10		60	°C
Supply Voltage			3.6		V
Current Consumption			110		mA
RF Frequency		CH1: 2414, CH2: 2432, CH3: 2450, CH4: 2468			MHz
LO Frequency		CH1:1934.5, CH2: 1952.5, CH3: 1970.5, CH4: 1988.5			MHz
Sensitivity			-80		dBm
IF Frequency			479.5		dBm
RF Gain(IF Amp. Include)			35		dB
Reference Frequency			8		MHz
Crystal Accruacy			30		ppm
RSSI Voltage	@ RFIN : -80~-10 dBm	0.19		2.1	V
Demodulation			FM		
Demodulator Input Sensitivity			-50		dBm
Demodulator Output Level			150		mVp-p
Audio Demodulator Input Level (LOPIP)			100		mVp-p
Audio Demodulator input Level (ROPIP)			100		mVp-p

Application Circuit: AWM638RX-1

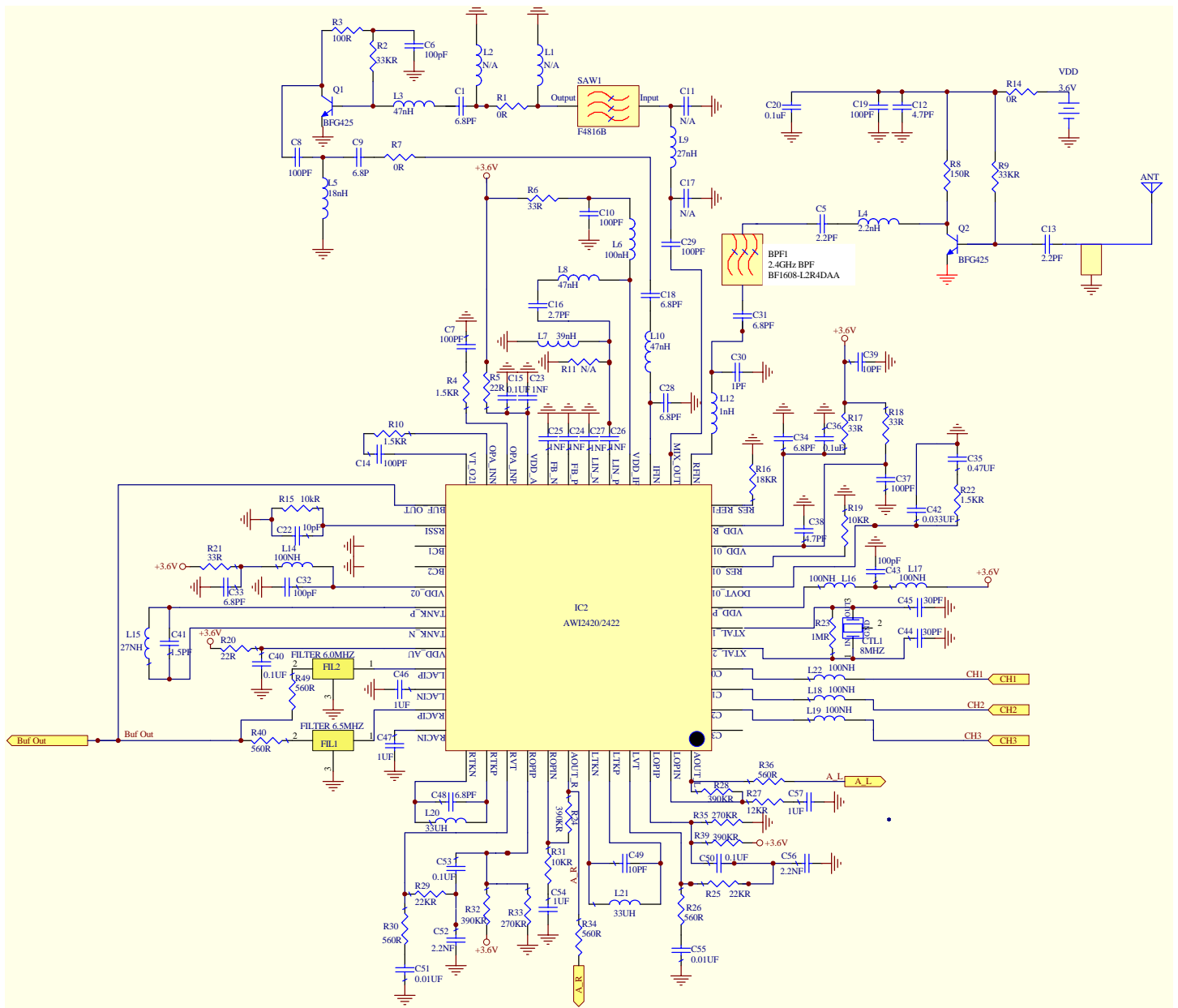

Application Circuit: AWM638RX-2

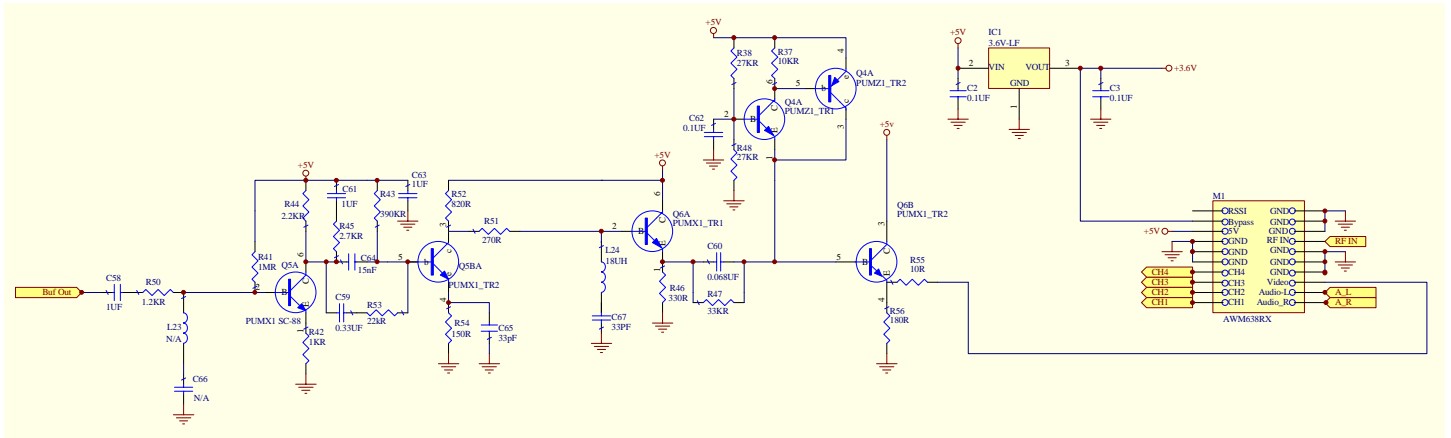

Package Information

QFN 48 Outline Dimensions

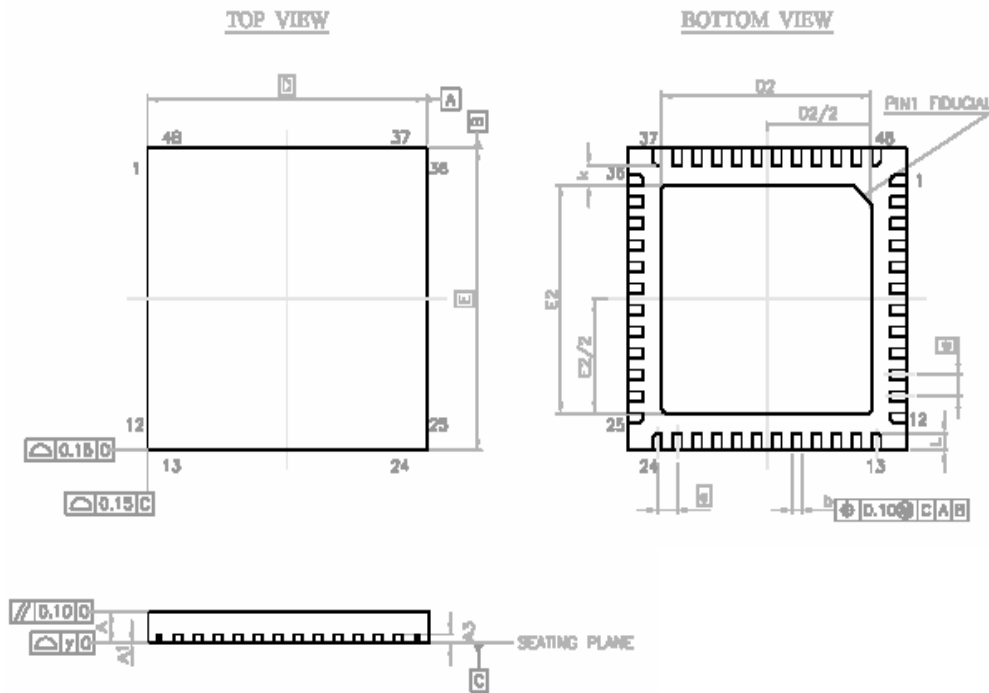

SYMBOL	DIMENSION (MM)			DIMENSION (MIL)		
	MIN.	NOM.	MAX.	MIN.	NOM.	MAX.
A	0.70	0.75	0.80	27.6	29.5	31.5
A1	0	0.02	0.05	0	0.79	1.97
A3	0.203 REF			8 REF		
b	0.38	0.25	0.30	7.1	9.8	11.8
D	7.00 BSC			276 BSC		
D2	5.10	5.20	5.30	201	205	209
E	7.00 BSC			276 BSC		
E2	5.10	5.20	5.30	201	205	209
a	0.50 BSC			19.7 BSC		
k	0.20			7.9		
L	0.30	0.40	0.50	11.8	15.7	19.7
y	0.08			3.15		